

No	Qty	DESCRIPTION	# MANARAS	REV
71	1	MOTOR 336, 337 OR 350	MOTOR	
72	1	OPERA POCKETWHEEL	POCKETWHEEL005	1
73	3	PIN SLOTTED SPRING 1/4 x 2	PIN011	
74	1	RADIO CONTROL TERM STRIP	TSTRIP005	
75	1	REDUCER CC63-40D FR. 56C	REDUCER030	
76	1	SHAFT 24UNEF LG. 10.085"	SHAFT105	2
77	1	SINGLE LIM. SW. AND LEVER	LIMIT001	
78	1	SINGLE SWIVEL PULLEY 1.0	PULLEY016	
79	1	SOLENOID	SOLENOID	
80	4	STD SINGLE LIMIT SWITCH	LIMIT015	
81	1	SUPPORT TSTRIP GEAR HEAD	BRACKET036	
82	1	TELEM. REVERS. CONT. 24V	CONTACTOR044	
83	1	TERMINAL STRIP 12 POSITIONS	TSTRIP001	
84	1	TOP DISCONNECT LEVER GH	LEVER062	4
85	1	TRANSFO 120/240-24 40VA	TRANSF143	
86	1	TROLLEY ARM DISCONNECT SPRING	SPRING026	
87	1	TYPE A PLAIN WASHER 1/4 N ZP	WASHER004	
88	1	TYPE A PLAIN WASHER 3/16 ZP	WASHER003	
89	6	TYPE A PLAIN WASHER 3/8 W ZP	WASHER010	
90	5	TYPE A PLAIN WASHER 5/8 N ZP	WASHER014	

No	Qty	DESCRIPTION	# MANARAS	REV
1	6	6-32 HEX NUT ZP	NUT002	
2	6	6-32 HEX NYLON LOCK NUT ZP	NUT018	
3	6	6-32 X 2 MACHINE SCREW	SCREW045	
4	8	6-32 X 3/8 TYPE F S-TAP. SCREW	SCREW094	
5	6	6-32 X 5/8 TYPE F S-TAP. SCREW	SCREW095	
6	2	8-32 HEX NUT ZP	NUT003	
7	2	8-32 X 3/8 MACHINE SCREW	SCREW049	
8	2	10-24 HEX NUT ZP	NUT004	
9	2	10-24 X 3/4 RND HD SO NECK BOLT	BOLT056	
10	12	10-24 X 3/8 TYPE F S-TAP. SCREW	SCREW022	
11	1	10-32 HEX NYLON LOCK NUT ZP	NUT019	
12	1	10-32 X 1/2 MACHINE SCREW	SCREW054	
13	1	#410-1R32P(INCL. IC/L)	CHAIN006	
14	1	#410-1R46P	---	
15	1	#50 CONNECTING LINK 50-1	LINK011	
16	6	1/4-20 HEX NUT ZP	NUT006	
17	5	1/4-20 HEX NYLON LOCK NUT ZP	NUT020	
18	3	1/4-20 X 1-1/2 HEX BOLT	BOLT008	
19	1	1/4-20 X 1-1/4 HEX BOLT	BOLT007	
20	1	1/4-20 X 1-1/4 RND HD SO NECK BOLT	BOLT083	
21	1	1/4-20 X 2-3/4 HEX BOLT	BOLT014	
22	5	1/4-20 X 3/4 HEX BOLT	BOLT002	
23	2	1/4-28 X 1/4 SET SCREW	SCREW002	
24	2	3/8-16 HEX JAM NUT ZP	NUT009	
25	4	3/8-16 HEX NUT ZP	NUT010	
26	12	3/8-16 X 1 HEX BOLT	BOLT023	
27	4	3/8-16 X 1-1/2 HEX BOLT	BOLT027	
28	1	410B18-1:1/4 K1/4-2SS/16	SPR410B18X1/4	2
29	1	410B9-5/8 K3-16-2S1/4	SPR410B9X5/8	
30	7	5/16-18 X 5/16 SET SCREW	SCREW003	
31	2	5/8-24 HEX JAM NUT ZP	NUT015	
32	2	BEARING CAST IRON 1 1/4X 1 5/8	BEARING013	
33	2	BEVEL GEAR GH MGH 5/8 20TH	GEAR001	2
34	1	BRAKE DRUM 5/8 WITH GROOVE	DRUM004	8
35	1	BRAKE LEVER PIVOT	BUSHING053	3
36	1	BRAKE SHOE ASS FOR STD BRAKE	BRAKEPART017	
37	2	CAM GUIDE PLATE SPRING C260047	SPRING001	
38	1	CARRIER DISCONNECT BRACKET	LEVER063	4
39	1	CHAIN GUIDE 6 3/8	GUIDE012	
40	2	COLLAR 5/8"	COLLAR004	
41	1	COTTER PIN 1/8 X 3	PIN002	
42	1	DPDT 24V RELAY	RELAY024	
43	1	EXTERNAL 3/4 RETAINING RING	CLIP006	
44	2	FLANGE BEARING 5/8 x10-221*3	BEARING005	
45	4	FLANGE BUSHING 5/8-3/4-1/2	BUSHING002	
46	1	GH CAM PLATE STANDARD	CAMPLATE001	5
47	1	GH HOIST SHAFT ASSEMBLY UNIV	SHAFT037	1
48	1	GH SELF ENG LEVER EXTEN B	BRACKET082	4
49	1	GH-MGH CONTROL BOX	CBOX001	10
50	1	GH-MGH-RCGH ADJUST BRAKE LEVER	LEVER052	1
51	1	GROUND LUG T616-UL	CONNECTOR039	
52	1	HAND CHAIN 31.4-19.5-1000	CHAIN002	
53	2	HELICAL SPRING LOCK WASH NO 10 ZP	WASHER025	
54	5	HELICAL SPRING LOCK WASH 1/4 ZP	WASHER026	
55	16	HELICAL SPRING LOCK WASH 3/8 ZP	WASHER030	
56	2	HELICAL SPRING LOCK WASH NO 8 ZP	WASHER024	
57	1	KEY 1/4 X 1	KW021	5
58	2	LIMIT CAM 5/8-24UNEF	CAM004	
59	1	LIMIT LEVER GEAR HEAD	LEVER067	2
60	4	LIMIT SWITCH SPACER 1/4 X 1/4	SPACER001	
61	1	MGH BRAKE LEVER C-1 GALVANIZED	LEVER051	
62	1	MGH BRAKE SUPPORT REDUCER 80	BRACKET169	3
63	1	MGH CONTROL BOX COVER	COVER001	
64	1	MGH CONTROL BOX MGMT BRACKET	BRACKET011	3
65	1	MGH FRONT COVER	COVER017	3
66	1	MGH HOIST DISC LEVER BR	BRACKET001	3
67	1	MGH LEFT FRAME 1HP	FRAME006	9
68	1	MGH RIGHT FRAME 1HP	FRAME005	9
69	1	MHG HOIST DISCONNECT LEVER GRN	LEVER001	5
70	1	MJ DISCONNECT HOIST SPRING	SPRING012	

No	Qty	DESCRIPTION	# MANARAS	REV
1	1	MGH 2HP RIGHT FRAME	FRAME001	10
2	1	MGH 2HP LEFT FRAME	FRAME002	10
5	1	MGH FRONT COVER 2HP-GREEN	COVER015	4
18	1	MGH CBOX SUPPORT	BRACKET009	2

PART DESCRIPTION  
**MGH THREE PHASES UP TO 1.5HP**

PART NUMBER  
**MGH**

MANARAS-OPERA  
 136 ONEIDA DRIVE  
 POINTE-CLAIRE, QC, H9R 1A8  
 TEL: 1-800-361-2260  
 FAX: 1-888-626-0606

MANARAS  
 Opera

DRAWN BY: M. BEAUCHEMIN  
 SHEET: 1 of 2

2001-02-22  
 2008-01-09

CONFIDENTIAL : THIS DRAWING AND/OR THE INFORMATION CONTAINED HEREIN IS AND REMAINS THE SOLE PROPERTY OF, AND IS PROPRIETARY TO, MANARAS-OPERA. THIS DRAWING AND/OR INFORMATION SHALL BE KEPT CONFIDENTIAL AND MAY NOT BE REPRODUCED, COPIED, MODIFIED, DISCLOSED, TRANSFERRED, OR MADE AVAILABLE TO OTHERS, EXCEPT WITH THE EXPRESS CONSENT OF MANARAS-OPERA. IT IS LOANED IN CONFIDENCE FOR MUTUAL ASSISTANCE PURPOSES ONLY. MANARAS-OPERA MAY AT ANY TIME, WRITTEN MODIFY THE DRAWING AND/OR INFORMATION CONTAINED HEREIN.

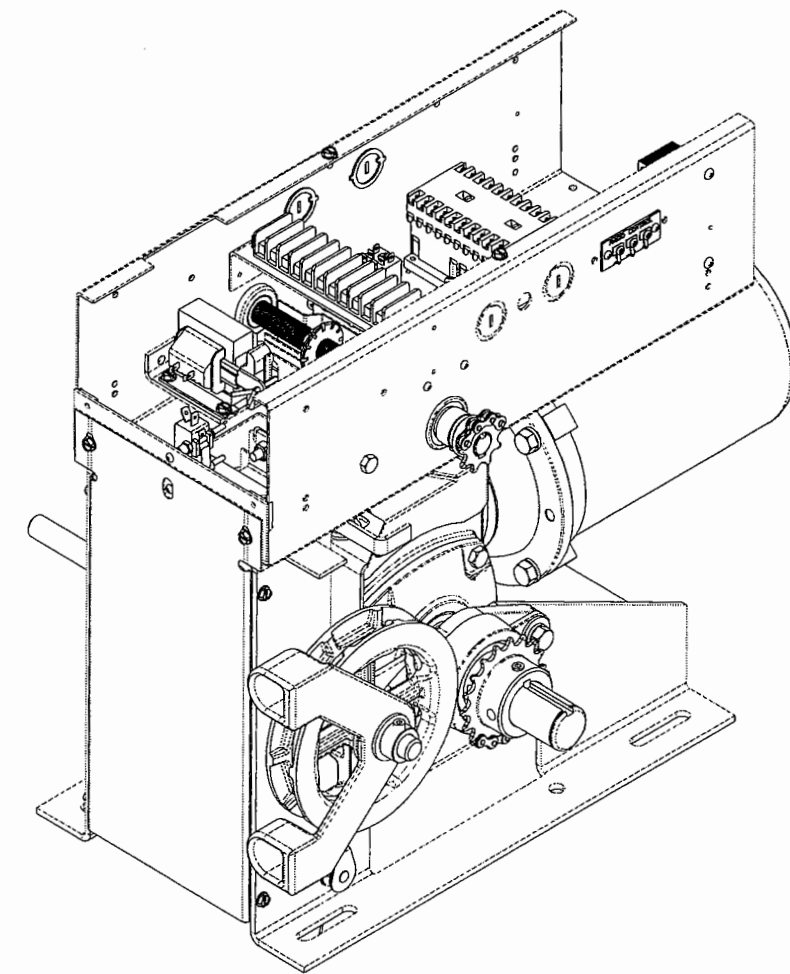
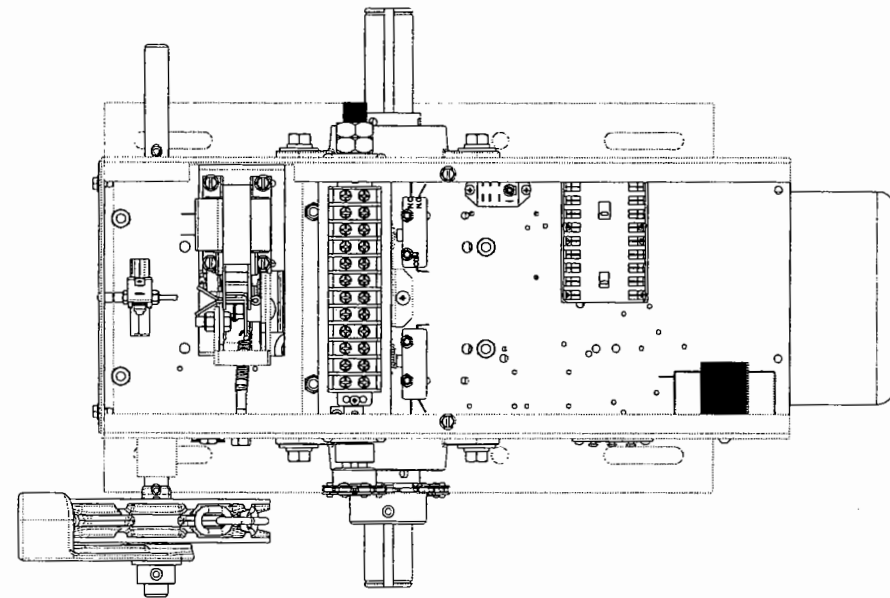
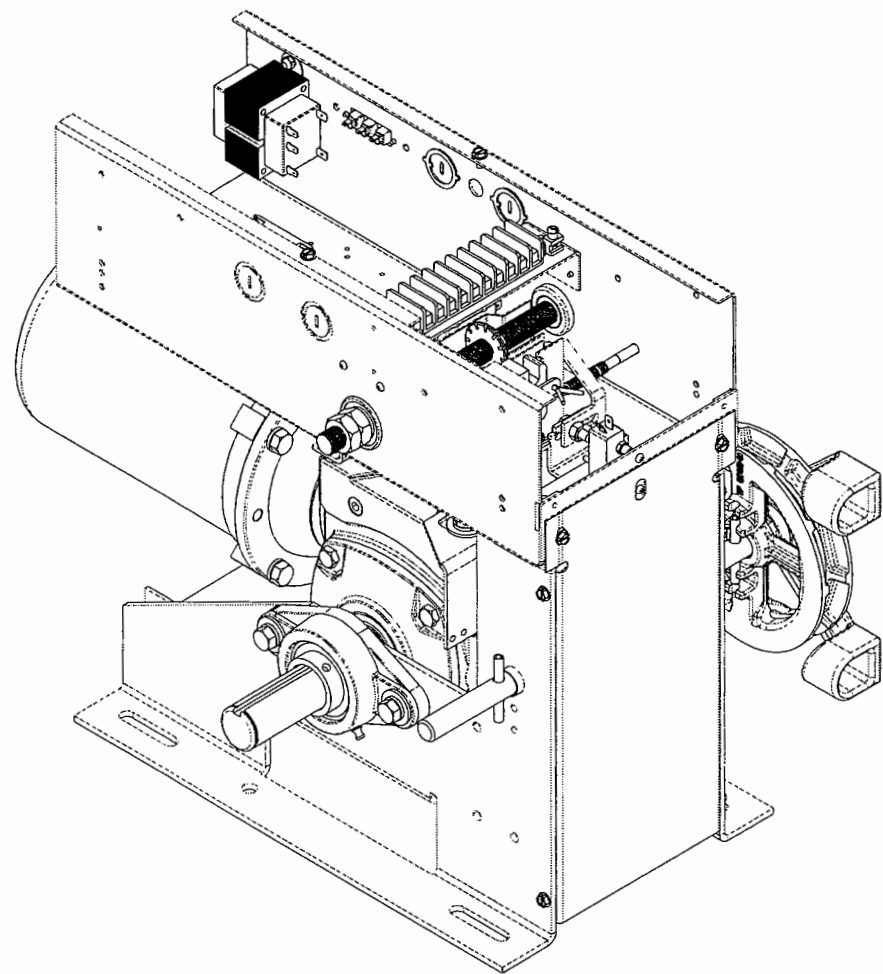

TOP AND ISO VIEWS SHOWN WITHOUT COVER001

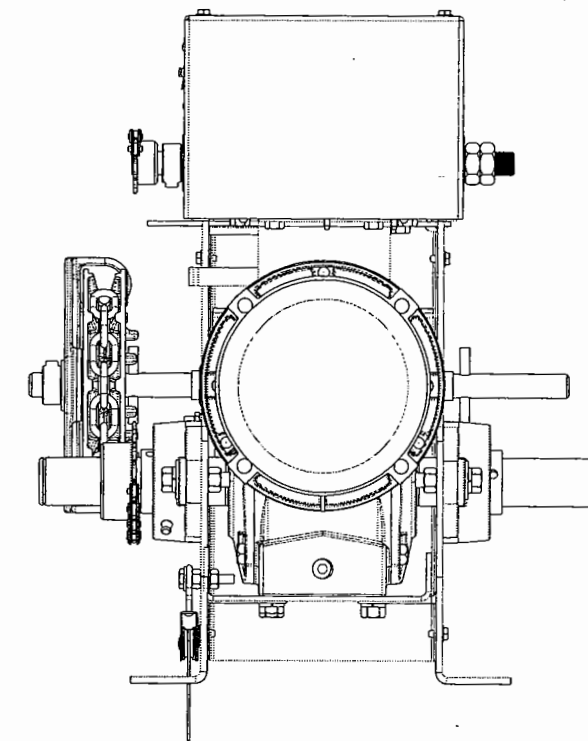
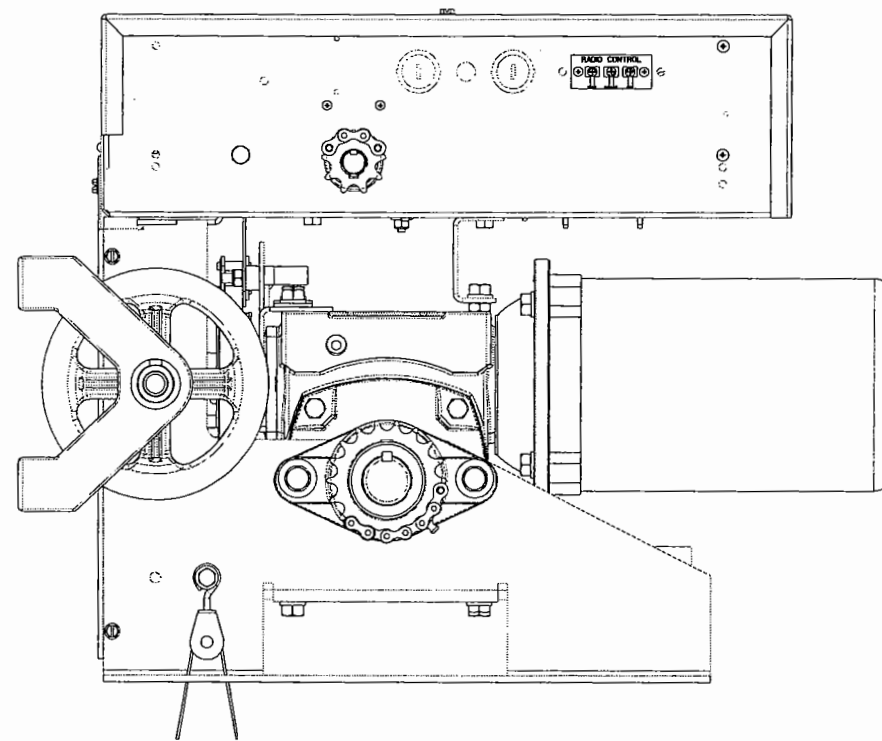
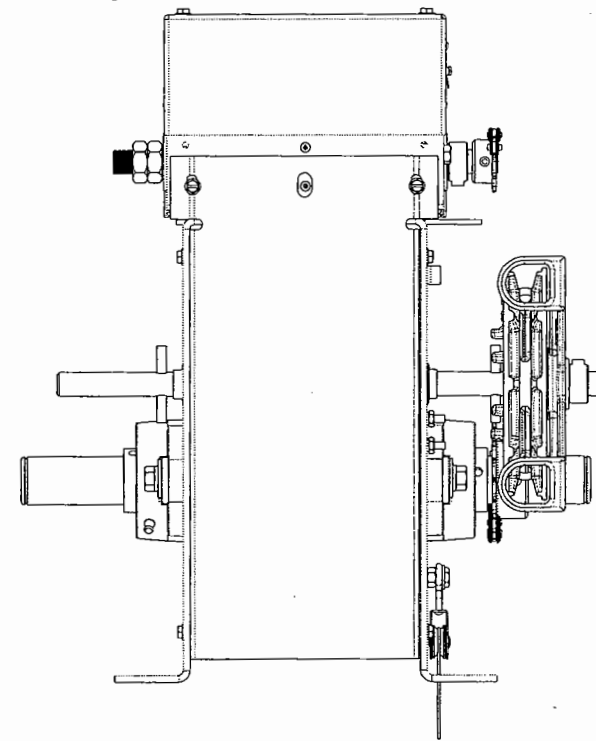

PART DESCRIPTION		
<b>MGH THREE PHASES UP TO 1.5HP</b>		
PART NUMBER	<b>MGH</b>	MANARAS-OPERA 136 ONEIDA DRIVE POINTE-CLAIRE, OC, H9R 1A8 TEL: 1-800-361-2260 FAX: 1-888-626-0606
DRAWN DATE:	2009-03-06	
LAST UPDATE:	2008-01-09	
INITIAL	G.T	
DRAWN BY:		SHEET:
G. THOMAS		2 of 2

**CONFIDENTIAL:** THIS DRAWING AND/OR THE INFORMATION CONTAINED HEREIN IS AND REMAINS THE SOLE PROPERTY OF, AND IS PROPRIETARY TO, MANARAS-OPERA. THIS DRAWING AND/OR INFORMATION SHALL BE KEPT CONFIDENTIAL AND MAY NOT BE REPRODUCED, COPIED, MODIFIED, DISCLOSED, TRANSFERRED, OR MADE AVAILABLE TO OTHERS, EXCEPT WITH THE EXPRESS CONSENT OF MANARAS-OPERA. IT IS LOANED IN CONFIDENCE FOR MUTUAL ASSISTANCE PURPOSES ONLY. MANARAS-OPERA MAY AT ANY TIME, WRITTEN MODIFY THE DRAWING AND/OR INFORMATION CONTAINED HEREIN.