

Customer:			
Project:			
Architect/Engineer:			
Contractor:			
Drawing No.:	Date:	Sheet	of

Shop Drawing

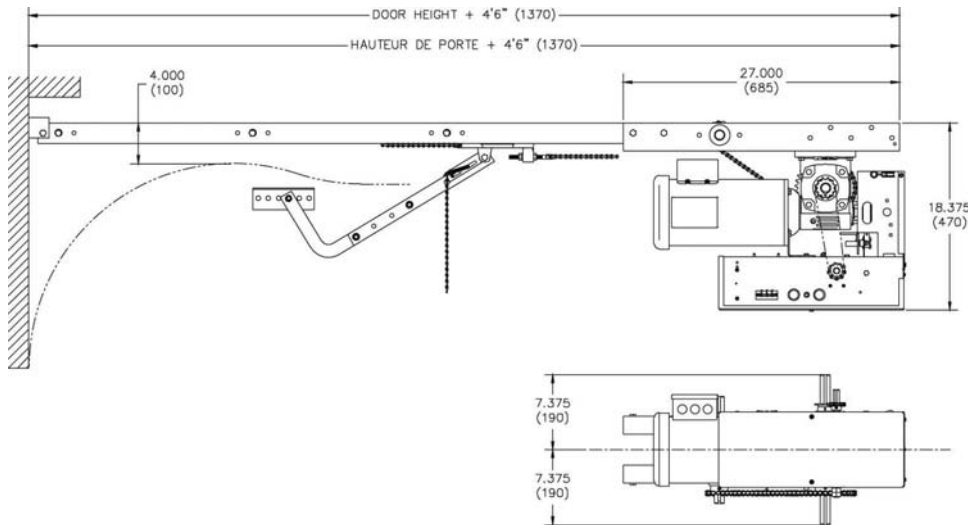

Motor Amperage Rating					
HP	Voltage - Phase				
	115 V - 1 Ph	230 V - 1 Ph	208 / 230 V - 3 Ph	460 V - 3 Ph	575 V - 3 Ph
1/2	9.0	4.5	2.2	1.1	-
3/4	11.2	5.6	3.2	1.5	1.2
1	13.6	6.8	3.7	1.7	1.4
1 1/2	19.6*	9.8	5.3	2.5	2.0

* ECB not available

• Specifications For Ordering

Quantity:	Model Number:			
HP:	Amperage:	Volts:	Phase:	Hertz:
Motor Circuit Type: (Circle One) Contactor or ECB				
Door Type:	Width:	Height:	Lift:	
Supply	3-Push Button Station(s) in NEMA		Enclosure Per Operator	

Supply Auxiliary and Optional Equipment as specified below: One per operator unless otherwise noted.

• Notes:

1. Refer to model MGT Specification Sheet for General Information
2. Refer to Drawing _____ for Wiring Diagram