

71	1	KEY 1/4 X 1	KW021	5
72	1	KEY 3/16 X 9/16	KW031	5
73	12	5/16-18 HEX NUT ZP	NUT007	
74	2	5/8-18 HEX JAM NUT ZP	NUT013	
75	4	6-32 HEX NYLON LOCK NUT ZP	NUT018	
76	1	10-32 HEX NYLON LOCK NUT ZP	NUT019	
77	2	1/4-20 HEX NYLON LOCK NUT ZP	NUT020	
78	1	PIN SLOTTED SPRING 1/4 X 1-3/4	PIN020	
79	1	PIN SLOTTED SPRING 5/16 X 2	PIN021	
80	1	DISCONNECT FORK AXLE	PIN022	
81	1	POP RIVET 1/8 X (0.126-0.187)	RIVET003	
82	3	POP RIVET 5/32 X (0.063-0.125)	RIVET004	
83	2	1/4-20 X 5/16 SET SCREW	SCREW001	
84	10	5/16-18 X 5/16 SET SCREW	SCREW003	
85	2	10-24 X 3/8 TYPE F S-TAP. SCREW	SCREW022	
86	1	10-24 X 3/4 TYPE F S-TAP. SCREW	SCREW023	
87	1	10-32 X 1/2 MACHINE SCREW	SCREW054	
88	8	6-32 X 3/8 TYPE F S-TAP. SCREW	SCREW094	
89	2	6-32 X 5/8 TYPE F S-TAP. SCREW	SCREW095	
90	4	6-32 X 7/8 TYPE F S-TAP. SCREW	SCREW096	
91	4	6-32 X 1-5/8	SCREW097	
92	1	10-32 X 3/16 SET SCREW	SCREW098	
93	7	BOARD SUPPORT 5/8"	SUPPORT001	
94	7	BOARD SUPPORT RIVET	SUPPORT002	
95	1	TYPE A PLAIN WASHER NO 8 ZP	WASHER002	
96	2	TYPE A PLAIN WASHER 3/16 ZP	WASHER003	
97	12	TYPE A PLAIN WASHER 1/4 W ZP	WASHER007	
98	3	TYPE A PLAIN WASHER 5/8 N ZP	WASHER014	
99	1	FLT WASHER 5/8 (.630X.955X.047) ZP	WASHER018	
100	12	HELICAL SPRING LOCK WASHER 5/16 ZP	WASHER028	
101	10	BELLEVILLE WASHER (31.5X16.3X0.8)	WASHER035	
102	1	FLT WASHER 5/8 (.640X1.18X.065) ZP	WASHER043	
103	1	TYPE B PLAIN WASHER No.4 R ALU	WASHER056	
104	1	OILITE WASHER (.625X1.00X.125)	WASHER057	
105	1	SHIM WASHER (.750X1.125X.031) ZP	WASHER058	
106	1	KEY 0.188 X 2.4 (INCL. W/ MOTOR)	KEY	
107	1	#410-1R32P(INCL.1CL)	CHAIN006	

No	Qty	DESCRIPTION	# MANARAS	REV
1	1	M.MRT 1/2 60 115/230 ODP 56Z	MOTOR254	
2	1	RIGHT HAND SIDE FOR OPERA	FRAME037	17
3	1	LEFT HAND SIDE FOR OPERA	FRAME038	17
4	1	OPERA CONTROL BOX	CBOX025	35
5	1	OPERA CONTROL BOX COVER	COVER047	8
6	1	OPERA OUTPUT SHAFT	SHAFT102	5
7	1	SHAFT #2 LIMIT SHAFT C12L14	SHAFT103	5
8	1	OPERA-HJ RIGHT INPUT SHAFT	SHAFT111	1
9	1	OPERA MOTOR PLATE	PLATE078	8
10	1	OPERA HANDLE	HANDLE005	8
11	1	DOUBLE SPROCKET OPERA 1"	SPR410B14A32X1	2
12	1	SPROCKET	SPR41B14A410B32X75	
13	1	SPR410B14A28X3/4	SPR410B14A28X3/4	
14	1	SPROCKET 41B32X1 PH5/16	SPR41B32X1P313	
15	1	SPROCKET 410B14 X 1K0 1S3/8	SPR410B14X1	
16	1	SPR410B9X3/8 2SS	SPR410B9X3/8	
17	1	MOTOR PULLEY 2.0 x 5/8 5L STL	PULLEY014	1
18	1	PULLEY 7" x 5/8" 5LB	PULLEY020	5
19	1	PW ASSEMBLY (ROLLERS AND CLIPS)	POCKETWHEEL007	
20	1	CHAIN GUIDE 6 3/8	GUIDE012	
21	1	CAM DISCONNECT OPERA	CAM010	6
22	1	COUPLING 3/4 2 PINS 1/4	COUPLING014	2
23	1	DISCONNECT FORK	FORK001	5
24	1	OPERA CBOX ARM L BRACKET	BRACKET181	3
25	1	FORK / SWITCH SUPPORT	BRACKET192	1
26	2	FLANGED BEARING 5/8	BEARING006	
27	2	FLANGE BEARING 1" C16-3F5	BEARING007	
28	1	FDGHE FW 5/8 ID x 11/8 TRA1018	BEARING024	
29	2	OPERA LIMIT SHAFT BUSHING	BUSHING055	1
30	1	OPERA DISCONNECT SPRING BUSHING	BUSHING056	2
31	1	DISCONNECT SWITCH SHOE "A"	SHOE009	5
32	1	DISCONNECT SWITCH SHOE	SHOE010	4
33	1	CL PAD 5/8x4x0.125"	CLUTCHPAD005	3
34	1	OPERA CLUTCHPLATE	CLUTCHPLATE006	3
35	1	OPERA CBOX CAMPLATE	CAMPLATE015	5
36	1	OPERA LIMIT LEVER	LEVER070	8
37	1	OPERA - CBOX ARM	ARM024	5
38	1	OPERA COVER ARM	ARM025	3
39	4	LIMIT SWITCH SPACER 1/4 X 1/4	SPACER001	
40	1	OPERA SPACER 3/4"	SPACER008	1
41	1	OPERA SPACER 1/8 X 1"	SPACER011	
42	1	CAM GUIDE PLATE SPRING C260047	SPRING001	
43	2	TOGGLE SWITCH SPRING	SPRING030	
44	1	OPERA CBOX ROD SPRING	SPRING039	6
45	1	OPERA - DISCONNECT SPRING	SPRING040	3
46	1	COMP. SPRING 1"ID 2"L	SPRING041	
47	1	EXT. SPRING 3/8 OD	SPRING042	
48	1	STD COMPLETE ELECT. CONTROL BOARD	BOARD060	
49	1	STD ELECT. POWER BOARD 2 RELAYS	BOARD066	
50	1	TRANSFO 120/240-24 40VA	TRANSF143	
51	1	RESET	RESET	
52	2	STD SINGLE CUT-OFF SWITCH	LIMIT019	
53	2	STD SINGLE CUT-OFF SWITCH	LIMIT020	
54	1	RADIO CONTROL TERM STRIP	TSTRIP005	
55	1	GROUND LUG TA61G-UL	CONNECTOR039	
56	1	ROD CBOX OPERA	ROD019	1
57	1	1/4-20 X 3/4 HEX BOLT	BOLT002	
58	12	5/16-18 X 3/4 RND HD SQ NECK BOLT	BOLT093	
59	1	1/4-20 X 1-3/4 RND HD SQ NECK BOLT	BOLT094	
60	1	CABLE STRAIN RELIEF 5/8 OD	BUSHING058	
61	1	7 X 7 1/16 X 16" CW STOP 1 END	CABLE012	
62	2	CAM LIMIT OPERA	CAM011	2
63	1	PUSH NUT 177-061	CLIP015	
64	1	PUSH NUT 1/4"	CLIP016	
65	1	STEEL COLLAR 0.375" IDX(22563)	COLLAR002	
66	2	COLLAR 5/8"	COLLAR004	
67	1	COLLAR 3/4	COLLAR005	
68	3	COLLAR 1"	COLLAR007	
69	1	S HOOK	HOOK001	

108	2	#410-1R48P(INCL.1CL)	CHAIN058	
109	1	#41-1R48P(INCL.1CL)	CHAIN059	
110	1	CABLE SLEEVE 1/16	SLEEVE001	
111	1	TYPE B, INSIDE LENGTH 29	VBELTB29	
112	1	KEY 3/16 X 1-1/2 ROUNDED ENDS	KW013	5
113	1	PIN SLOTTED SPRING 3/16 X 2	PIN008	
114	1	FLT WASHER 1/4 (.268X.75X.062) ZP	WASHER061	

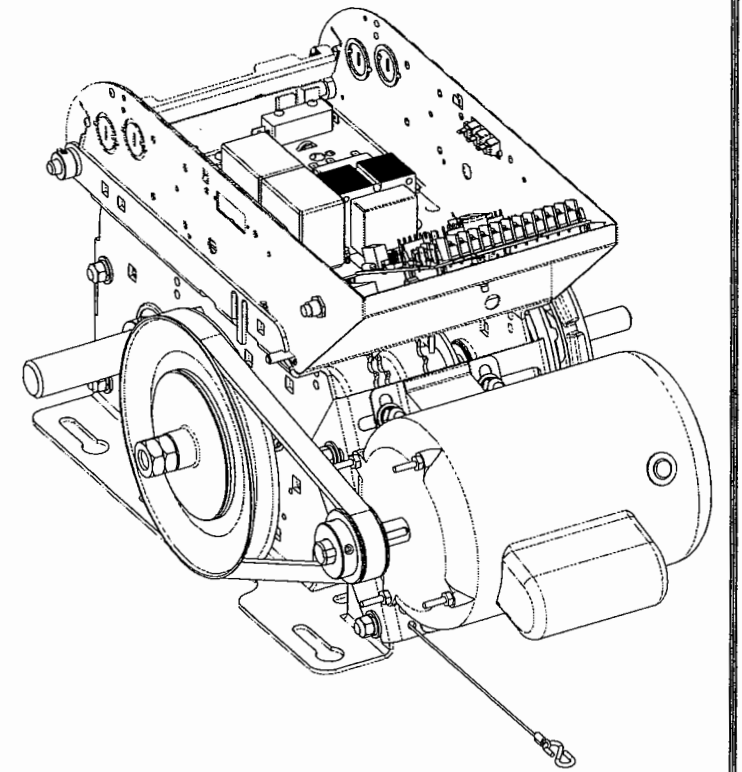
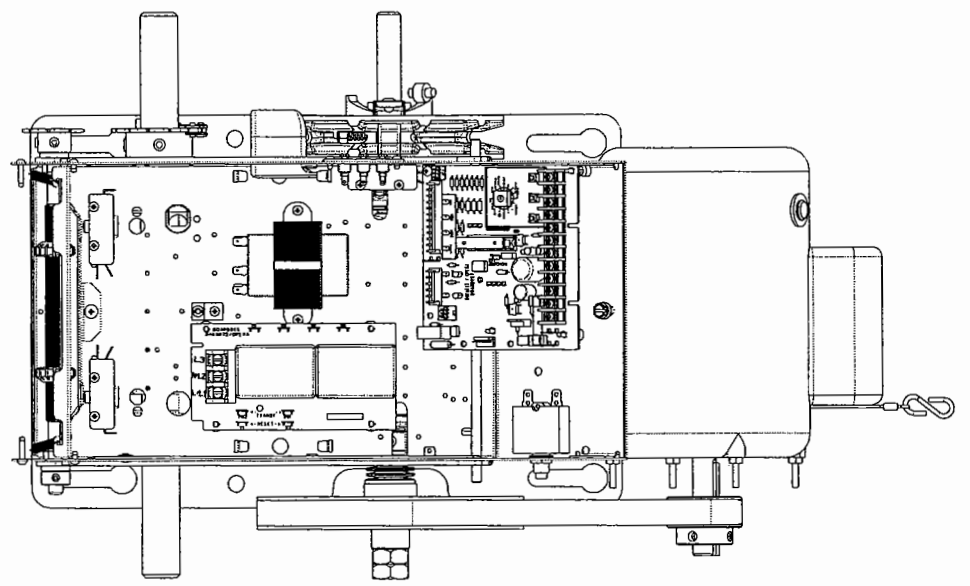
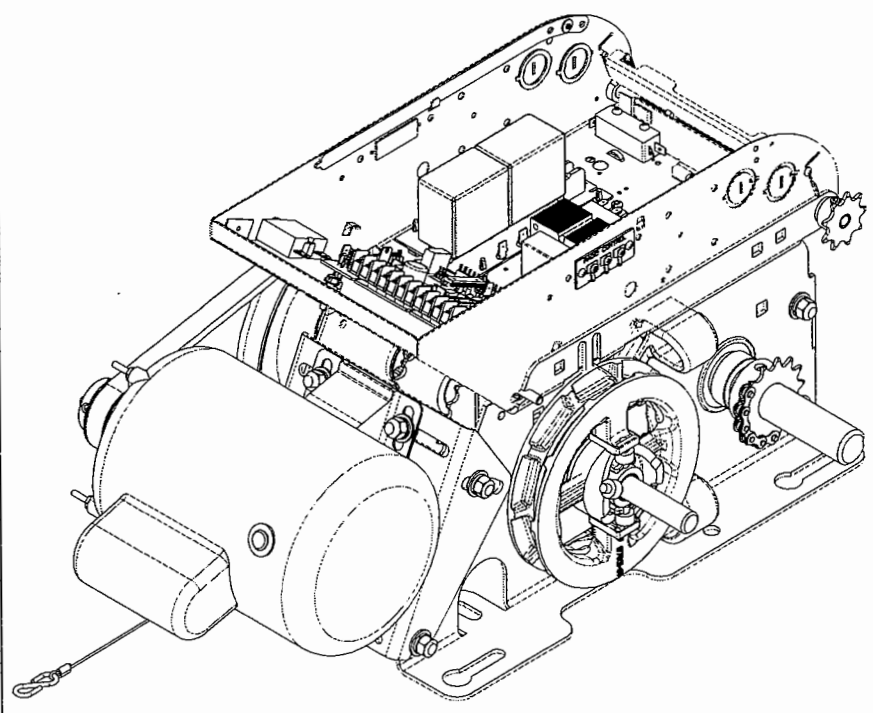

CONFIDENTIAL: THIS DRAWING AND/OR THE INFORMATION CONTAINED HEREIN IS AND REMAINS THE SOLE PROPERTY OF, AND IS PROPRIETARY TO, MANARAS-OPERA. THIS DRAWING AND/OR INFORMATION SHALL BE KEPT CONFIDENTIAL AND MAY NOT BE REPRODUCED, COPIED, MODIFIED, DISCLOSED, TRANSFERRED, OR MADE AVAILABLE TO OTHERS, EXCEPT WITH THE EXPRESS CONSENT OF MANARAS-OPERA. IT IS LOANED IN CONFIDENCE FOR MUTUAL ASSISTANCE PURPOSES ONLY. MANARAS-OPERA MAY AT ANY TIME, WRITTEN MODIFY THE DRAWING AND/OR INFORMATION CONTAINED HEREIN.

PART DESCRIPTION			
OPERA-HJ SINGLE PHASE			
PART NUMBER	OPERA-HJ	MANARAS-OPERA	136 ONEIDA DRIVE
DRAWN DATE:	2007-08-13	POINTE-CLAIRE, QC, H9R 1A8	TEL: 1-800-361-2260
LAST UPDATE:	2009-04-01	FAX: 1-888-626-0606	
INITIAL	G.T	DRAWN BY:	N. BELANGER
		SHEET:	1 of 2

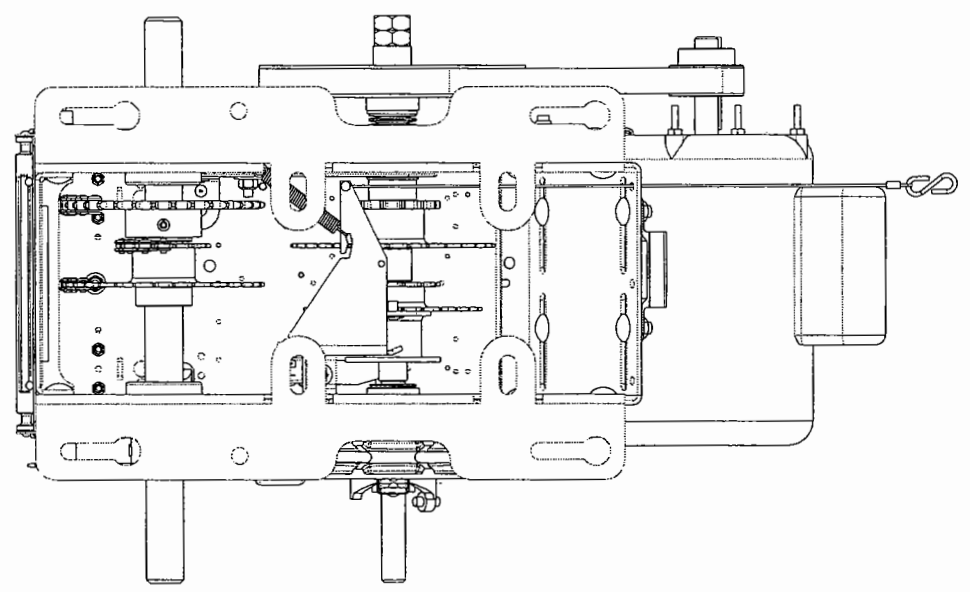
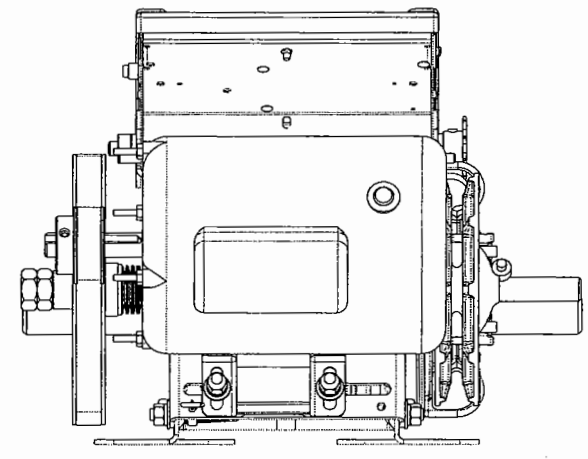
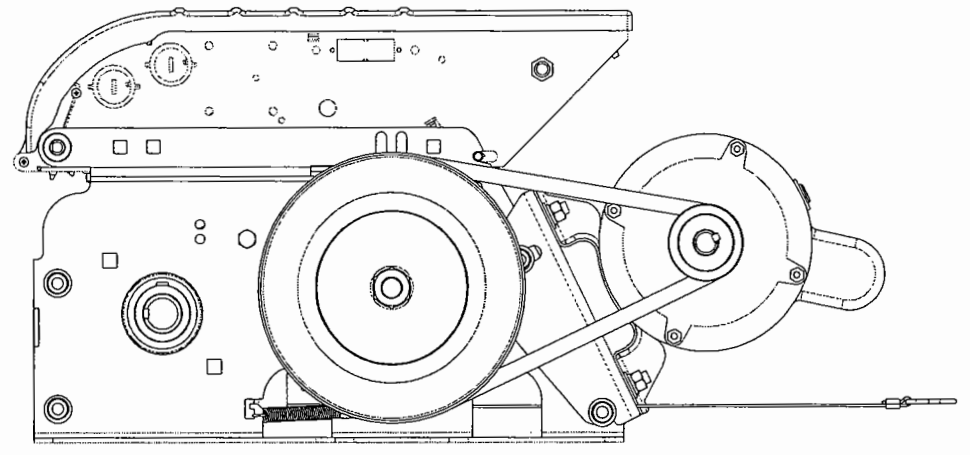
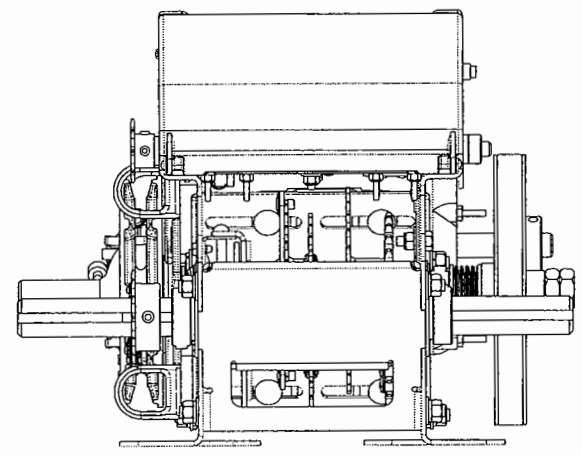

TOP AND ISO VIEWS SHOWN WITHOUT COVER047



PART DESCRIPTION		 
OPERA-HJ SINGLE PHASE		
PART NUMBER		MANARAS-OPERA 136 ONEIDA DRIVE POINTE-CLAIRE, QC, H9R 1A8 TEL: 1-800-361-2260 FAX: 1-888-626-0606
OPERA-HJ		
DRAWN DATE:		
2008-09-02		
LAST UPDATE:	INITIAL	DRAWN BY: G. THOMAS SHEET: 2 of 2
2009-04-01	G.T	

CONFIDENTIAL: THIS DRAWING AND/OR THE INFORMATION CONTAINED HEREIN IS AND REMAINS THE SOLE PROPERTY OF, AND IS PROPRIETARY TO, MANARAS-OPERA. THIS DRAWING AND/OR INFORMATION SHALL BE KEPT CONFIDENTIAL AND MAY NOT BE REPRODUCED, COPIED, MODIFIED, DISCLOSED, TRANSFERRED, OR MADE AVAILABLE TO OTHERS, EXCEPT WITH THE EXPRESS CONSENT OF MANARAS-OPERA. IT IS LOANED IN CONFIDENCE FOR MUTUAL ASSISTANCE PURPOSES ONLY. MANARAS-OPERA MAY AT ANY TIME, WRITTEN MODIFY THE DRAWING AND/OR INFORMATION CONTAINED HEREIN.