

Product Announcement

New Drum Brake For High Cycle Trolleys MOD 113

Drum
Brake ▶▶▶

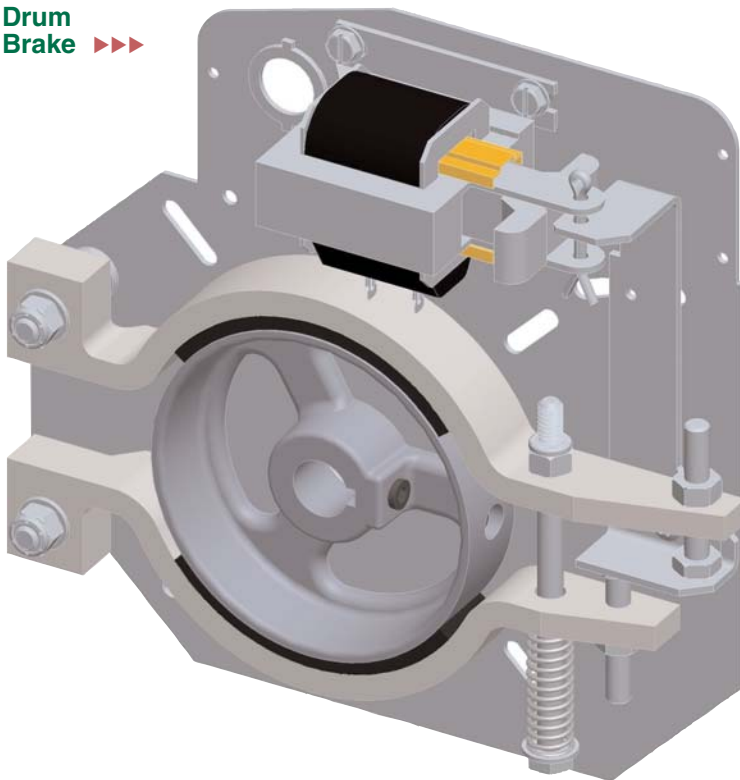

Manaras/Opera New Drum Brake MOD 113

Responding to your needs, Manaras/Opera will be offering an optional Drum Brake for High Cycle Trolley applications beginning February 1st 2007.

The drum brake modification (MOD 113) is an available option for models: MTBH, APT and APE.

Features of the Drum Brake

- Increased lifetime in comparison to existing band brake for high cycle applications.
- The amount of time before the first brake adjustment is increased.
- The tension placed on the solenoid is reduced, therefore increasing its lifetime.
- The brake has a smoother operation.
- The drum brake is also available as an assembly kit (BRAKE 014) for existing operator upgrades.

Please note that the models listed above will continue to be manufactured with the standard band brake unless MOD 113 is specified on the order.

For codification and pricing, please contact your sales representative.

MOD 113 and BRAKE 014 will be available as of February 1st 2007.
For further information, please contact your Manaras/Opera sales representative.

Toll free number: 800 - 361 - 2260
www.manaras.com