

Product Specification Sheet

DT-SERIES

DIRECT DRIVE JACKSHAFT OPERATOR FOR
COUNTERBALANCED SECTIONAL DOORS

STANDARD FEATURES

- **Motor:**
Inverter-duty rated, 1HP 3-phase motor, totally enclosed (TENV), IP-55.
- **Reduction:**
High-end worm gear reducer (synthetic oil).
- **Brake:**
24Vdc disk brake (integrated in motor). Manual brake release. Brake torque: 5 Nm (45 lbs in).
- **Manual Operation:**
Hand crank with cutoff switch. Hand crank storage integrated within operator.
- **Limit System:**
Single-turn mechanical limit system.
- **Environmental Protection:**
TENV electrical motor IP-55.
- **Mounting:**
Direct-mount hollow shaft (Ø 25.4 mm (Ø 1")), on right or on left of the door. Torque arm bracket (shown in dimension drawing) supplied with operator.
- **Wiring:**
Pre-wired power and control cables.
- **Duty Cycle:**
50%.
- **Temperature Range:**
Working temperature between 0°C to 40°C (32°F to 104°F).
- **Shipping Weight:**
Approx. 45 lbs - 20.4 kg (1HP model).
- **Warranty:**
2 years.

Inverter-Duty Rated Electrical Motor

High-Quality Hollow Shaft Direct Drive Worm Gear Reducer

Separate Control Panel

Direct on-line or variable frequency drive control available



The DT-Series operator is specifically designed for counterbalanced sectional door applications where optimized performance, reliability, speed and lifespan are required.

The operator features a very heavy-duty worm gear hollow shaft reducer with a built-in limit system.

Inverter-duty rated motor for VFD applications. Control panel sold separately.



MEMBER OF THE CANIMEX Group

When you think
Commercial Door OPERATORS,
just think OPERA.

800-361-2260
info@manaras.com
www.manaras.com

CONTROL OPTIONS

- **Separate Industrial Control Panels:**

Direct on-line or variable frequency drive control available. Logic options and special features available on demand. Upgraded control panel with braking resistor required for doors exceeding 750 lbs - 340 kg.

CERTIFICATIONS



- **Industrial Control Panels:** cCSAus

- **Electrical Motor:** cCSAus, cURus, CE

MAIN OPTIONS

- **Harsh Environmental Protection**

For further specifications or questions, please consult inside sales.

DIMENSIONS

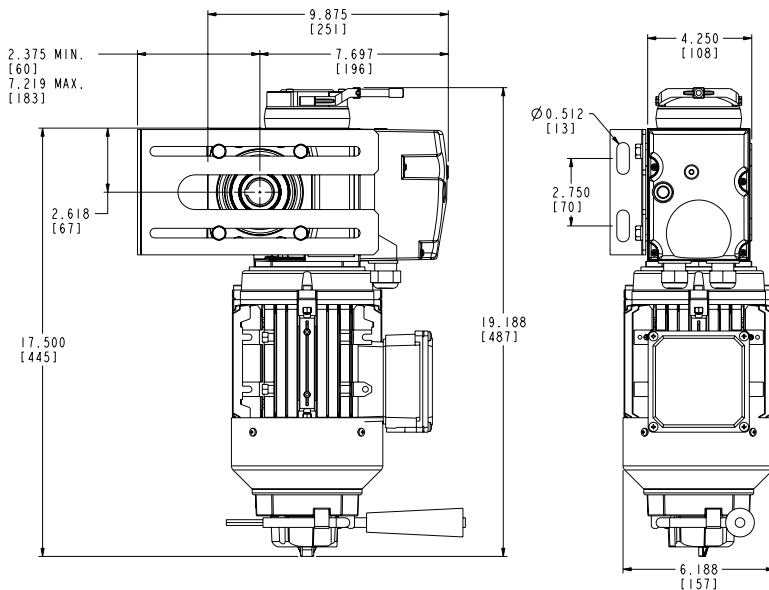

OPERATOR RANGE

	STD			FVL			HL				
	D400-144	D525-216	D800-384	D850-132	D1100-216	D1350-336	D400-54	D525-54	D575-120	D6375-164	D800-120
Door Height (ft.)	12.3	19.2	32.4	10.8	18.2	27.5	14.5	19.4	21.9	32.7	32.1
Max Speed Up To (ips)	11	14	22	21	24	24	14	18	23	24	24

General Guideline