

# Product Specification Sheet



## RAPIDO RTBH-1.23

TROLLEY OPERATOR FOR  
FAST STANDARD LIFT SECTIONAL DOORS

### STANDARD FEATURES

- **Electrical Supply:**  
Single-phase powered operator.
- **Motor:**  
60Hz high starting torque, continuous-duty, switchless motor, open drip proof, protected against overload.
- **Speed Managing Features:**  
Speed managing device provides enhanced performance and speed, with soft-start and soft-stop capabilities.
- **Reduction:**  
First step in reduction Bx section cogged V-belt drive, additional step by #41 chain and sprockets. Input shaft is 5/8", supported by cast iron flanged pillow block bearings. Output shaft is 1", supported by cast iron flanged pillow block bearings. Offers an opening door travel of 23"/sec and 15"/sec while closing.
- **Drive and Trolley Assembly:**  
#41 roller chain drive. Dual, 12 gauge, pre-drilled galvanized tracks provided for doors up to 12ft. in height standard. Additional track lengths are available (max. door height acceptable for the operator limit system is 30ft.). Track spacers 3/4" steel shaft. Trolley made of cast aluminum alloy with chain tension adjustment device.
- **Clutch:**  
Friction type, positioned on input shaft, easily adjustable from outside.
- **Brake:**  
Electrically activated drum-band type solenoid brake.
- **Manual Operation:**  
Quick release disconnect arm for manual door operation.
- **Electrical Enclosure:**  
All electrical components are in a Nema 1 enclosure. Hinged electrical enclosure cover.
- **Limit System:**  
Rotary-type oil-impregnated steel cams, commercial grade switches. Limit shaft is supported by self-lubricating bronze bushings for increased precision. Remains in time when there is a manual operation or after the motor has been removed.
- **Accu-cam® Features:**  
Precise and quick one-handed adjustment of the limits.
- **Non-Resettable Cycle Counter:**  
6-digit electro-mechanical counter, mounted inside the control box, counts each complete door cycle providing valuable data for maintenance scheduling.
- **Corrosion Protection:**  
Frame and control enclosure protected by baked on, long lasting enamel finish. All shafts protected by yellow chromate coating.
- **Mounting:**  
Ceiling-mounted with 8.69" headroom clearance required below the tracks.
- **Temperature Range:**  
Working temperature between 0°C to 40°C (32°F to 104°F).
- **Shipping Weight:**  
Approx. 73 Lbs - 33 Kg + tracks.
- **Warranty**  
2 Years.



### Manages Soft-Starts and Soft-Stops

Improves the longevity of the complete door system

### Speed Managing Device

Enhancing performance

### Single Phase Input Power / Switchless Motor

### Cast Iron Flanged Pillow Block Bearings

Support the input and the output shafts

### Accu-cam® Limit Feature

For precise and quick one-hand limit setting adjustments

### Accelerated Door Opening Speed

Increased door opening speed at 23"/sec<sup>1</sup>

**The Rapido RTBH is a high-speed heavy-duty trolley operator designed for use on on properly counter-balanced industrial standard lift sectional doors.<sup>2</sup>**

**The RTBH offers increased speed capabilities in comparison to a standard trolley operator while smoothly managing Soft-Starts and Soft-Stops, therefore reducing the wear and tear of the complete door system. It also incorporates a drum-band type solenoid brake.**

**The Manaras-Opera control is based on its legendary Electronic Control Board which delivers high performance and reliability while providing on-board control plus speed managing features.**



When you think  
Commercial Door OPERATORS,  
just think OPERA.

800-361-2260  
info@manaras.com  
www.manaras.com

## CONTROL OPTIONS

### • ECB Units (BOARD 070):

24Vdc relaying circuit with a 40VA class II transformer, non-volatile memory. Features available: On-board radio receiver, 1.5s delay on reverse, programmable maximum run timer, mid-stop, timer to close (suspension possible from floor level), independent input loop terminal, advance close system, test buttons, reverse wiring detection and door lock sensor. Operating mode selectable on site: C2, B2, D1, E2, T or TS.

### • "M" Version:

Provides the monitoring of Primary External Entrapment Protection Devices. Includes monitored Nema 4X photo cells (PHOTO 061 standard). In this mode, Ancillary Entrapment Protection Devices (optional) may be used to supplement primary entrapment protection, such as non-monitored photo cells, 2-wire non-monitored sensing edges and pneumatic sensing edges. Certifications: ANSI / CAN / UL 325:2017.

Note: CSA C22.2-247.92 and UL325 apply to units intended to be used in ordinary locations in accordance with the Canadian Electrical Code, Part I and the National Electrical Code, NFPA 70, respectively.

## MAIN OPTIONS

### • Control Accessories:

Angled terminal strip allows for the connection of 3-button stations (one supplied with the operator), non-monitored sensing edges, non-monitored photo cells, one push-button radio control (external strip), ceiling pull switches, key switches, loop detectors, external interlocks, universal auxiliary output module. 2A fuse protected 24VAC output is available for accessory power supply.

### • Control Modifications:

Alternate control available with separate control panel, optional separate brake resistor, transformer panel 480V to 240V/600V to 240V etc... consult inside sales.

### • Mechanical Modifications:

Dual trolley drive, trolley hoist, very heavy-duty front idler, minimum depth mounting, etc...consult inside sales.

### • Electrical Modifications:

Warning light wiring, contactor-ecb driven, etc...consult inside sales.

### • Environmental Modifications:

Available for Nema 4/12 type applications with separate control panel, nickel plated chain, birds nest protection, etc... consult inside sales.

## SUGGESTED APPLICATIONS

- Apartment Complexes / Office Buildings
- First Responder / Emergency Vehicle Facilities
- Automotive Dealerships / Transportation Facilities
- Airports / Military Facilities
- Energy Management / Energy Efficient / LEED Buildings

## DIMENSIONS

**Back Room:** Door height + 4'5" (1350mm)

**Head Room For Tracks:** 5.625" (143mm) above the highest point of door travel

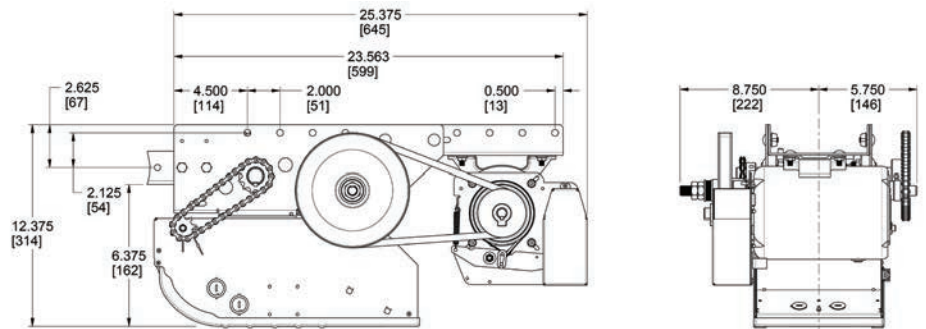

## OPERATOR RANGE

### Current Consumption (Amp.)

Horse Power	120V 1 Ph	208V 1Ph	240V 1 Ph
1	16.7	7.0	8.0

General Guideline

<sup>1</sup>Compared to standard OTBH at 12"/sec.

<sup>2</sup>For doors weighing above 750 Lbs, the system requires a brake resistor (\$).

**\*\* For additional specifications and in order to optimize the operator's performance, please contact our inside sales department for assistance in selecting the appropriate hardware kit for your application. \*\***

